

XLINE

ARCHITECTURAL LOW GLARE LINEAR FIXTURE

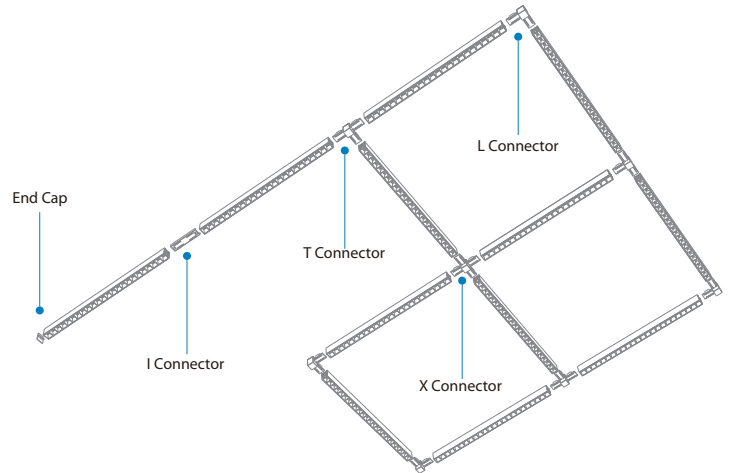
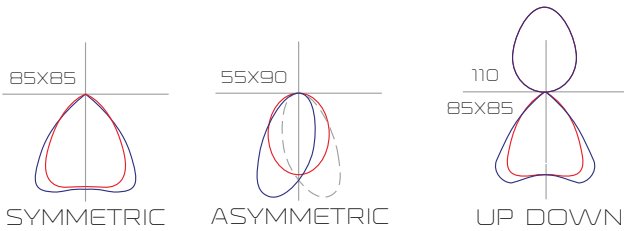
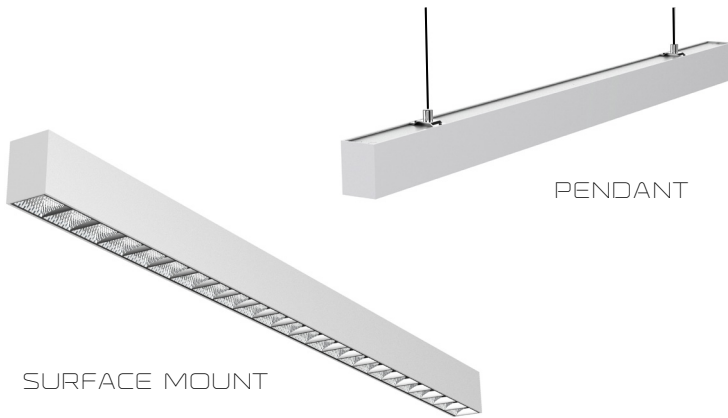

Seamless linear modules with a choice of two module lengths.
 Connection options - I, T, L and X configurations.
 Louvred with lense for ultimate glare and optical control.
 On board and remote driver options.
 On board - DALI and Switch.
 Remote mount - 1-10vdc, Wireless and Phase Cut.
 Mounting options - Surface, Suspended and Track.

Mounting Options

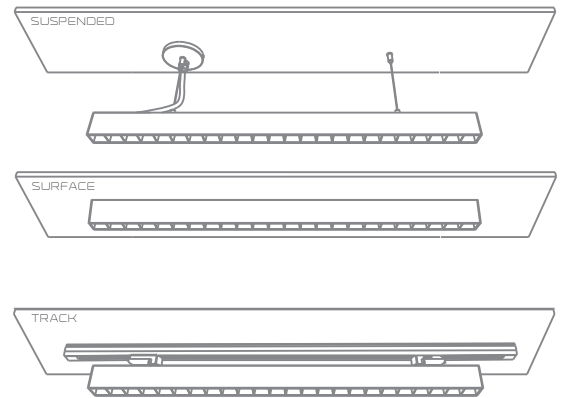

Base Material	Aluminium
Base Finish	Powder Coated Black
Louvre & Lense	Vacuum Aluminium & PC - (Poly Carbonate)
System Efficacy	111 lumens per Watt
Dimensions	Module 1 Length - 1,164mm Module 2 Length - 2,328mm Height - 61mm / Width - 46mm
Beam Angles	85° x 85°, 55° x 90°, 85° x 85° / 110°
End Treatment	Metal Caps
Mounting	Metal Clips/Joiners/Suspension

Connector Options

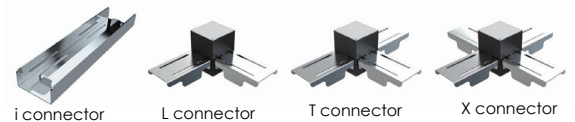

Data based on 4000K.

	Module 1 - 1164mm			Module 2 - 2328mm		
Current	400mA	500mA	600mA	800mA	1000mA	1200mA
Watts	14.4	18	21.6	28.8	36	43.2
Lm/Module	1598	1998	2397	3197	3996	4795
Lm/Metre	1373	1717	2060	1373	1717	2060

